

Twin Hood Type Pass Through Dishwasher

AMXT-10B

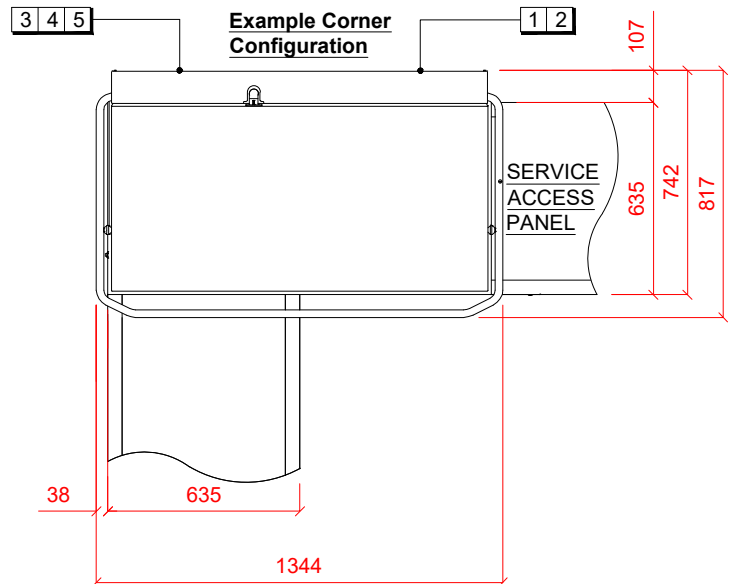
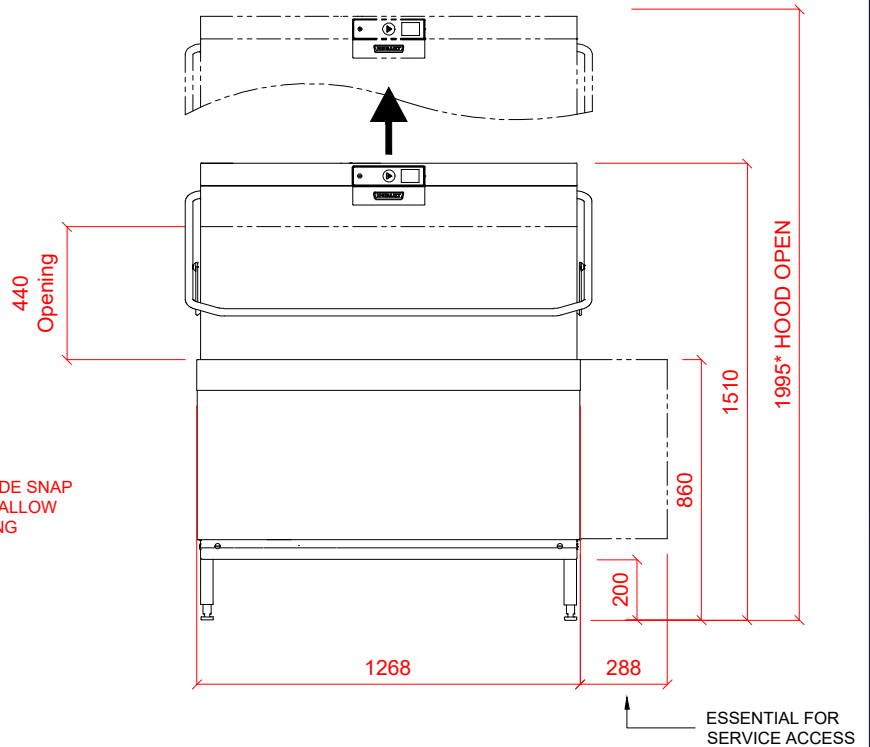
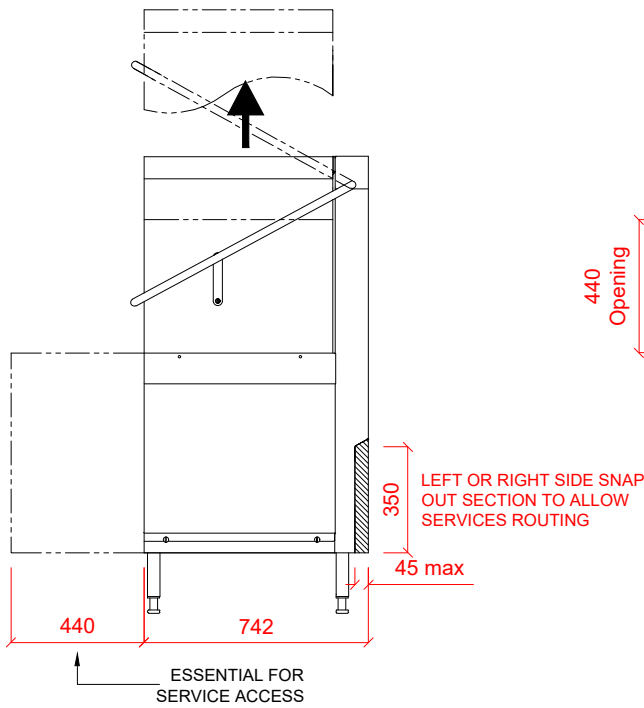

1 Water

22mm CONNECTION VIA 2 METRE FLEXIBLE HOSE, FEMALE TERMINATION.
WATER SUPPLY 10°C TO 50°C (2 TO 8° CLARK) @ 0.5 TO 10 BAR MAX. FOR 12.4kW BOOSTER HEATING.
OR
WATER SUPPLY 50°C (2 TO 8° CLARK) @ 0.5 TO 10 BAR MAX. FOR 6.2kW BOOSTER HEATING.
INITIAL TANK FILL 40 LITRES. RINSE WATER USAGE 4.0 LITRES PER CYCLE. MAX USAGE 240 LITRES PER HOUR.
OUR MACHINES ARE SUPPLIED WITH CLASS 'AB' AIR GAP AS STANDARD.

2 Drain

DRAIN - 2 METER FLEXIBLE HOSE TO A 40mm TRAPPED STANDPIPE UP TO 750mm MAX A.F.F.L.
FLOW RATE 30 LITRES PER MINUTE.
DRAIN RATE TYPICALLY 3 MINUTES.

3 Electric

19.4kW 400/50/3 + N + E
FUSED AT 32amps / PHASE.
CONFIGURABLE TO:
12.5kW 400/50/3 + N + E FUSED AT 20amps/ PHASE.
SUPPLIED WITH 2.5 METRES OF CABLE.

Other Services

RINSE AGENT HOSE - 2.5 METRE FLEXIBLE.
DETERGENT HOSE - 2.5 METRE FLEXIBLE.

Notes

Approx Weights: EMPTY: 180kg WITH WATER: 212kg
Min distance to Wall to Inside of tabling boxed edge 154.5mm.
HEIGHTS MARKED * REPRESENT ±20mm.