

ESSENTIAL FOR SERVICE ACCESS

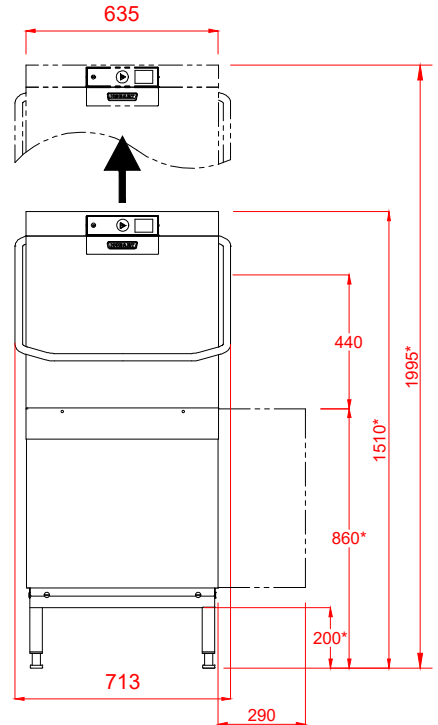

ESSENTIAL FOR SERVICE ACCESS

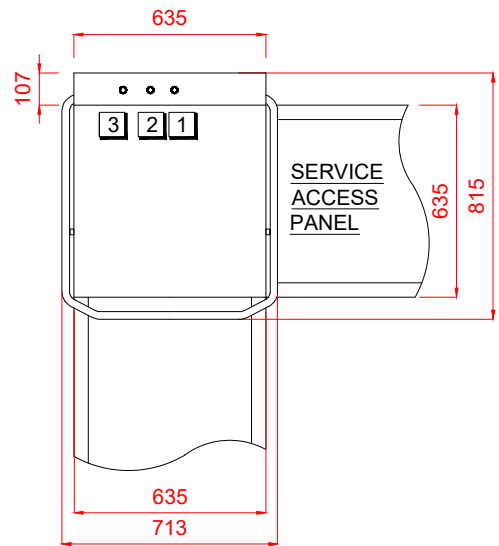

1 Water

22mm CONNECTION VIA 2 METRE FLEXIBLE HOSE, FEMALE TERMINATION.
COLD WATER SUPPLY 10°C (2° TO 8° CLARK MAX) @ 0.8 TO 10.0 BAR MAX.
OR: HOT WATER SUPPLY 60°C (2° TO 8° CLARK MAX) @ 0.8 TO 10.0 BAR MAX.
INITIAL TANK FILL 40 LITRES.
RINSE WATER USAGE 2.0 LITRES PER CYCLE.
MAX USAGE 140 LITRES PER HOUR.
OUR MACHINES ARE SUPPLIED WITH CLASS 'AB' AIR GAP AS STANDARD.

2 Drain

DRAIN - 2 METER FLEXIBLE HOSE TO A 40mm TRAPPED STANDPIPE UP TO 750mm MAX A.F.F.L.
FLOW RATE 30 LITRES PER MINUTE.
DRAIN RATE TYPICALLY 3 MINUTES.

Other Services

RINSE AGENT HOSE - 2.5 METRE FLEXIBLE.
DETERGENT HOSE - 2.5 METRE FLEXIBLE.

3 Electric

16.3kW 400/50/3 + N + E FUSED AT 32amps / PHASE. MACHINE SUPPLIED WITH 2.5 METRES OF CABLE (3 PHASE).
CONFIGURABLE TO:
10.1kW 400/50/3 FUSED AT 25amps

Notes

Approx Weights: EMPTY: 110kg WITH WATER: 130kg
Min distance to Wall to Inside of tabling boxed edge 154.5mm.
HEIGHTS MARKED * REPRESENT ±20mm.