

ECOMAX PLUS SERIES

HOOD TYPE



Hood Type Dishwasher

ECO+H615-10D

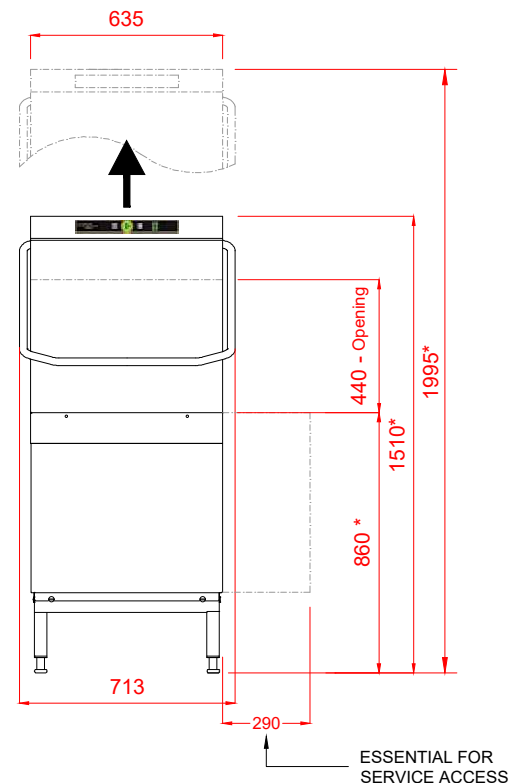
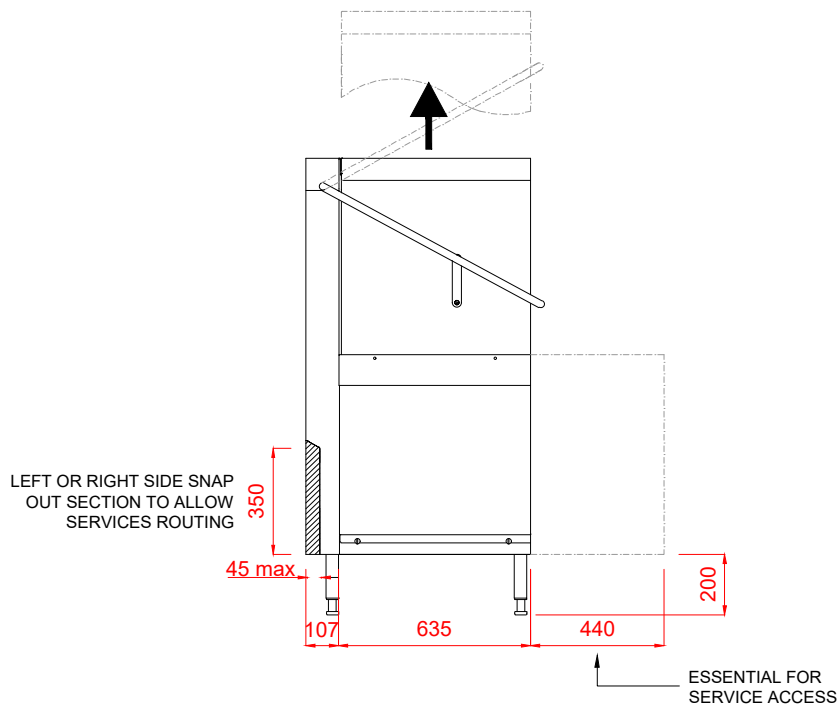
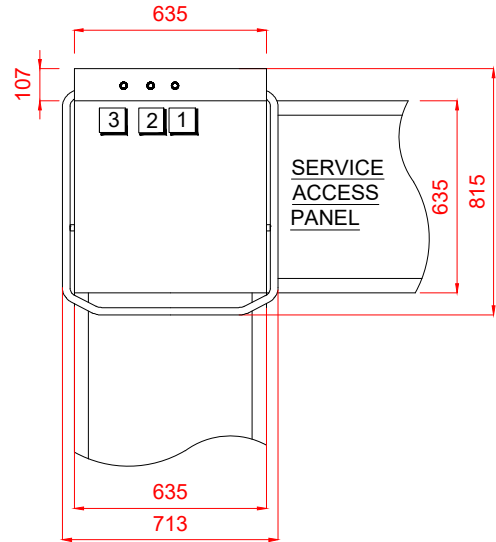

1 Water

22mm CONNECTION VIA 2 METRE FLEXIBLE HOSE, FEMALE TERMINATION.

WATER SUPPLY 60°C (2° TO 8° CLARK MAX) @ 0.5 TO 10.0 BAR MAX. INITIAL TANK FILL 23 LITRES.

RINSE WATER USAGE 2.2 LITRES PER CYCLE. MAX USAGE 60 CYCLES PER HOUR.

OUR MACHINES ARE SUPPLIED WITH CLASS 'AB' AIR GAP AS STANDARD.

2 Drain

DRAIN - 2 METRE FLEXIBLE HOSE TO A 40 mm TRAPPED STANDPIPE 750mm MAX A.F.F.L.

FLOW RATE 30 LITRES PER MINUTE.

Other Services

RINSE AGENT HOSE - 2.0 METRE FLEXIBLE. DETERGENT HOSE - 2.0 METRE FLEXIBLE.

3 Electric

7.0kW 400/50/3 + N + E FUSED AT 16amps / PHASE.

CONFIGURABLE TO:

4.9kW 230/50/1 FUSED AT 25amps

MACHINE SUPPLIED WITH 2.5 METRES OF CABLE.

Notes

APPROX WEIGHTS: EMPTY: 108kg's WITH WATER: 140kg's HEIGHTS MARKED * REPRESENT ±20mm. MIN DISTANCE FROM WALL TO INSIDE OF TABLING BOXED EDGE 154.5mm

PLOT SCALE: 1:25

RIGHT TO MAKE NECESSARY CHANGES IS RESERVED