



HOSHIZAKI

IM-100PE

Cuber, Self Contained

Production Capacity (kg/24h) approx. (AT 10°C, WT 10°C): 104

Storage bin capacity (kg) approx.: 50



ICE TYPE: Large cubes, Standard

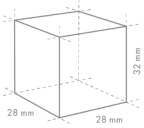

Cube Size: **L-STANDARD**
Weight: 23 g

ACCESSORIES INCLUDED

Scoop, installation kit, legs

OPTIONAL ACCESSORIES

4HC-H water filtration, scoop holder kit, UV-C sanitization kit, internal drain pump (Pump motor kit and bracket)

CORRESPONDING WATER FILTERS

4HC-H Single Water Filter, 4HC Replacement Cartridge

PRODUCT SERIES: IM CUBE

ITEM NUMBER: M114

COUNTRY OF ORIGIN: UK

Hoshizaki IM-100PE Cube model is a self-contained ice maker producing up to 104kg of cube ice per 24 hours.

Ice cube dimensions and weight - disclaimer: The drawing is for illustration purposes only. Cube size and weight may be differ due to local installation conditions.

- Ice making system with an automatic rinse cycle
- Each ice cycle is made with fresh water
- Closed Cell System helps produce compact, hard and geometrically perfect ice
- Closed water circuit for contamination protection
- Easy external access to control panel
- UV-C sanitization function is retrofittable
- Internal drain pump is retrofittable
- System comes with a magnetic DC water pump with variable speed that has no direct coupling, which prevents any leakage
- Cleanable air filter
- Removable door gasket
- Easily removable water pan assembly

WARRANTY PERIOD

3 Years on Parts & Labour

EXTERIOR

**Stainless steel 430,
Galvanized steel (Rear)**

Refrigerant: R290 / Refrigerant (kg): 0.14 / CO2 equivalent (kg): 0.42

OPERATING CONDITIONS

Ambient Temp.: 1-40°C, Water Supply Temp.: 5-35°C, Water Supply Pressure: 0.07-0.8MPa (0.7-8bar), Voltage Range: Rated Voltage ±6%

CERTIFICATIONS





HOSHIZAKI

IM-100PE

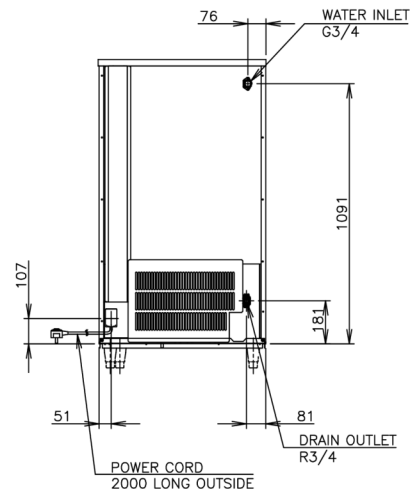
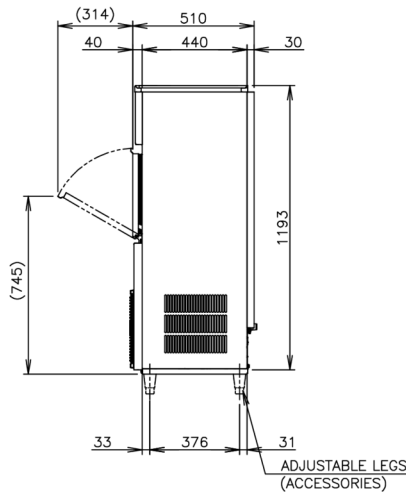
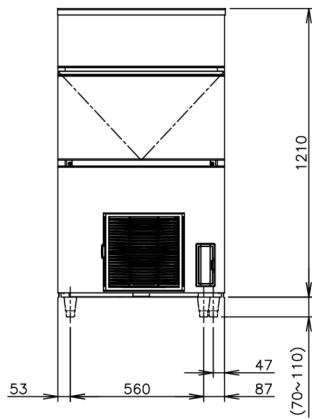
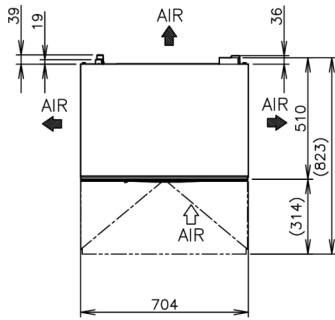

TECHNICAL SPECIFICATIONS

| Cooling System | Production Capacity (kg/24h) approx. (AT 10°C, WT 10°C) | Production Capacity (kg/24h) approx. (AT 21°C WT 15°C) | Production Capacity (kg/24h) approx. (AT 32°C WT 21°C) | Power Supply | Electrical Circuit Breaker Protection (A) | Electric Consumption (kW) | Water Consumption (m ³ /24h) approx. (AT 10°C WT 10°C) | Heat Rejection (AT 32°C, WT 21°C) (kW) |
|----------------|---|--|--|-------------------|---|---------------------------|---|--|
| Air Cooled | 104 | 98 | 81 | 1/220 - 240V/50Hz | 5 | 0.485 | 0.39 | 1.19 |

SHIPPING SPECIFICATIONS

| Dimensions W x D x H (mm), legs excluded | Dimensions of Legs (mm) | Net Weight (kg) | Dimensions, Packed, W x D x H (mm) | Gross Weight, Packed (kg) | Volume Packed (m ³) |
|--|-------------------------|-----------------|------------------------------------|---------------------------|---------------------------------|
| 704 x 506 x 1210 | for legs add 70-110mm | 71 | 805 x 580 x 1375 | 83 | 0.642 |

Disclaimer: Every effort has been made to ensure that the information contained in this spec sheet is accurate at the time of publishing. Hoshizaki Europe BV assumes no responsibility or liability for typographical errors or omissions or for any misinterpretation of the information within the publication and reserves the right to change without notice.



HOSHIZAKI